

AKAI SERVICE MANUAL

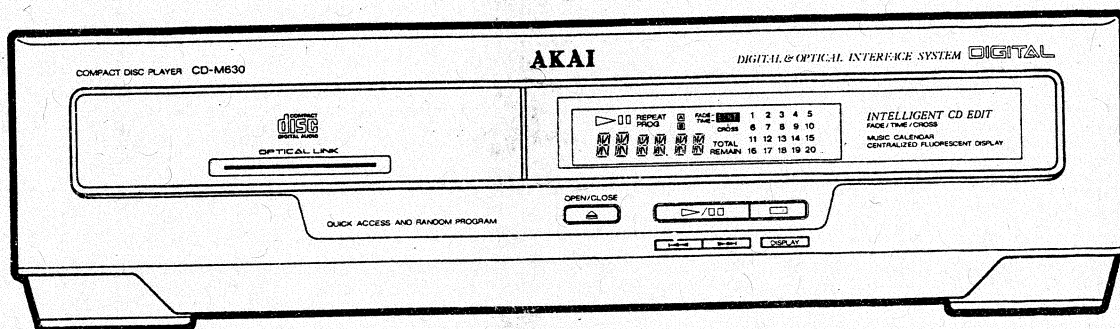

COMPACT DISC PLAYER

MODEL **CD-M630**

SPECIFICATIONS

Pick up	3 beam laser pick up
Error correction system	Cross interleave reed solomon
Number of channels	2 channel stereo
Wow & flutter	Less than measurable limits
Optical output level	- 22 dBm / 660 nm
Power requirements	Supplied from amplifier (model AX-M430 / AM-M630 / AM-M830)
Dimensions	360 (W) × 95 (H) × 295 (D) mm
Weight	2.6 kg

Standard accessories

Optical cable	×1
Operator's manual	×1

* For improvement purposes, specifications and design are subject to change without notice.

★ SAFETY INSTRUCTIONS

PRECAUTIONS DURING SERVICING

- Parts identified by the \triangle (*) symbol are critical for safety. Replace only with parts number specified.
- In addition to safety, other parts and assemblies are specified for conformance with such regulations as those applying to spurious radiation. These must also be replaced only with specified replacements.
Examples: RF converters, tuner units, antenna selector switches, RF cables, noise blocking capacitors, noise blocking filters, etc.
- Use specified internal wiring. Note especially:
 - Wires covered with PVC tubing
 - Double insulated wires
 - High voltage leads
- Use specified insulating materials for hazardous live parts. Note especially:
 - Insulation Tape
 - PVC tubing
 - Spacers (Insulating Barriers)
 - Insulation sheets for transistors
 - Plastic screws for fixing microswitch (especially in turntable)
- When replacing AC primary side components (transformers, power cords, noise blocking capacitors, etc.), wrap ends of wires securely about the terminals before soldering.

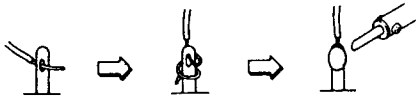

- Observe that wires do not contact heat producing parts (heatsinks, oxide metal film resistors, fusible resistors, etc.).

- Check that replaced wires do not contact sharp edged or pointed parts.
- Also check areas surrounding repaired locations.
- Use care that foreign objects (screws, solder droplets, etc.) do not remain inside the set.

SAFETY CHECK AFTER SERVICING

After servicing, make measurements of leakage-current or resistance in order to determine that exposed parts are acceptably insulated from the supply circuit.

The leakage-current measurement should be done between accessible metal parts (such as chassis, ground terminal, microphone jacks, signal-input/output connectors, etc.) and the earth ground through a resistor of 1500 ohms paralleled with a 0.15 μ F capacitor, under the unit's normal working conditions. The leakage-current should be less than 0.5 mA rms AC.

The resistance measurement should be done between accessible exposed metal parts and power cord plug prongs with the power switch (if included) "ON". The resistance should be more than 2.2 Mohms.

★ INFORMATION

PRECAUTIONS BEFORE/AFTER REPAIRING THE UNIT

[ABOUT THE POWER SUPPLY]

Power supply and power control data for the CD-M630 are supplied from the amplifier and tuner. Therefore when repair of the CD-M630 is necessary, repair should be made together with the amplifier and tuner.
To repair the CD-M630 without the tuner, use the following procedure, it can be repaired together with the amplifier only.

- When amplifier is AM-M630 or AM-M830
While pushing G.E REC button on the amplifier, press the POWER button on the amplifier to turn the power of the amplifier on.
- When amplifier is AX-M430
While pushing the PLAY (\blacktriangleright) button, press the POWER button to turn the power of the AX-M430 on.

While pushing the DISPLAY and \blacktriangleright buttons simultaneously on the CD-M630, connect the flat connection cable from the CD-M630 to the amplifier to turn the power of the CD-M630 on.

To turn off the power of the amplifier and CD-M630, the AC power cord must be disconnected.

[ABOUT THE TRANSPORT LOCKING PLUG]

This CD player has transport locking plugs located on the bottom panel. These plugs are locks the laser pick up mechanism to prevent vibration during transportation. Before playback, make sure to remove the locking plugs. Before transporting the unit, make sure to remove the compact disc, and insert the transport locking plugs to lock the laser pick up mechanism.

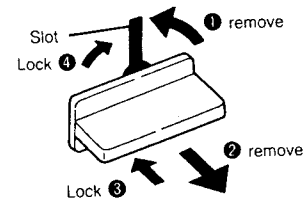

[EUROPE, SCANDINAVIA, UK and AUSTRALIA]

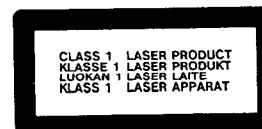

Label affixed on the rear panel of the unit

[PRECAUTIONS IN REPAIRING]

When repairing or adjusting the unit, please note the following points.

- Do not put excessive pressure on the mechanical parts (operation parts), including the pick up block, as extremely high mechanical precision is required in these parts.
- When the base is removed for repair or adjustment, make sure that there are no metal objects in the narrow gap between the P.C boards or the mecha. parts and the base.
- The micro-computer and the CD signal processing ICs can be damaged by static electricity or leakage from a soldering iron during repair. While soldering, use a low leakage (anti static) type soldering iron or take precautions against leakage as in the illustration below.

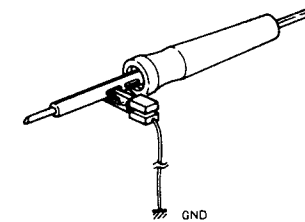

- Do not loosen any screws in the pick up block. When handling the pick up block, please refer NOTE or CAUTION accompanying the explanation of procedure.
- For your own safety, avoid hazardous invisible laser radiation. Do not look at the laser beam (objective lens) directly.
- On models for some countries, laser warning labels are affixed on the outside and inside the unit as shown below. For your own safety, read these labels carefully when repairing or adjusting the unit.

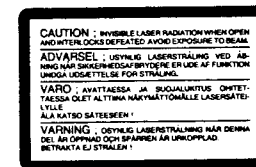

Label advand on the disc clamber inside the unit

I. DISASSEMBLY

In case of trouble, etc., necessitating dismantling, please dismantle in the order shown in the illustrations. Reassemble in reverse order.

1. Removal of the UPPER COVER

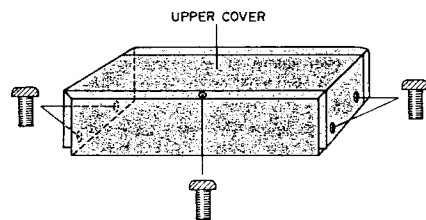

2. Removal of the DISC TRAY

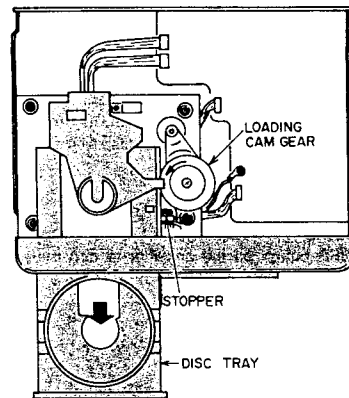

- 1) Set the DISC TRAY to EJECT position by turning the LOADING CAM GEAR counter-clockwise, then pull out the DISC TRAY while pushing the DISC TRAY STOPPER down.

3. Removal of the MECHA BLOCK

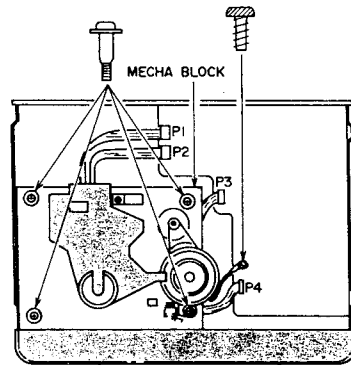

[NOTE]

Before disconnecting the connectors P1 and P2 to remove the MECHA. BLK, make sure that the P.C board on the PICK UP BLOCK has been short circuited (refer to 3-2. REPLACEMENT OF THE PICK UP BLOCK).

II. PRINCIPAL PARTS LOCATION

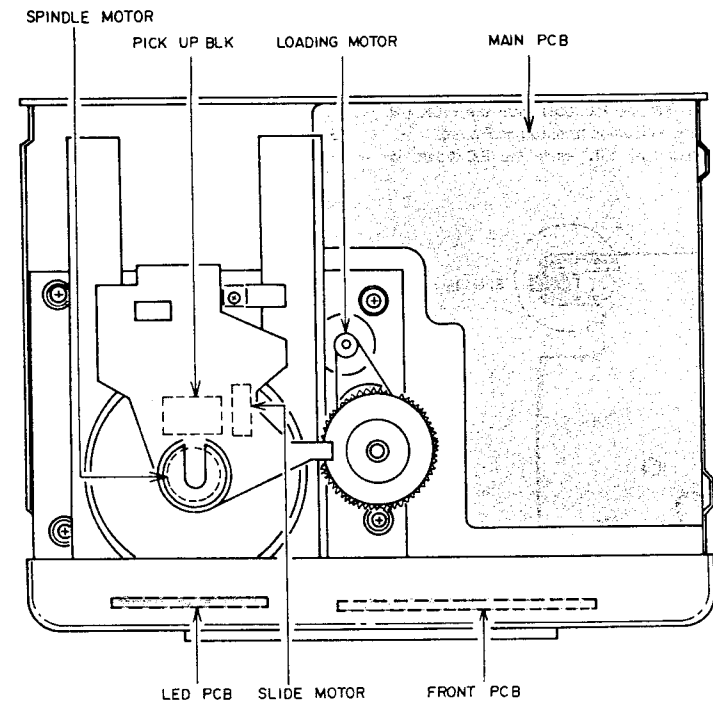

Fig. 2-1 Top view

III. REPLACEMENT OF THE PICK UP BLOCK AND MOTORS

NOTE: For your own safety, avoid hazardous invisible laser radiation. Make sure that the power switch is OFF when removing the DISC CLAMPER.

3-1. REMOVAL OF THE DISC CLAMPER

- 1) Remove the DISC CLAMPER by pulling it up and moving it to left.

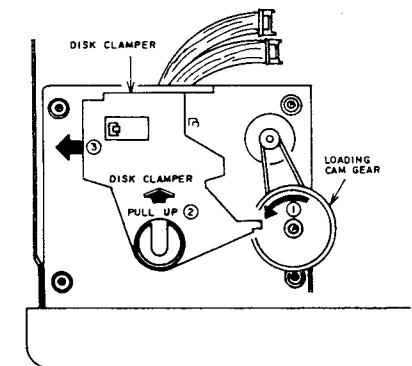

Fig. 3-1

3-2. REPLACEMENT OF THE PICK UP BLOCK

[PRECAUTION BEFORE REMOVING THE PICK UP BLOCK]

When disconnecting or connecting the connectors P1 and P2, make sure that the P.C board (on the PICK UP BLOCK) has been short circuited as shown in Fig. 3-2. Do not turn the electricity "ON" while the P.C board is short circuited.

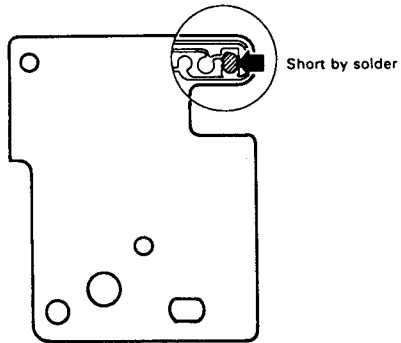

Fig. 3-2

- 1) Disconnect the connectors P1 and P2 on the PICK UP BLOCK.
- 2) Push the ③ part of the pick up block SLIDE SHAFT and pull it in the arrowed direction to remove the PICK UP BLOCK.
- 3) Reassemble in reverse order.

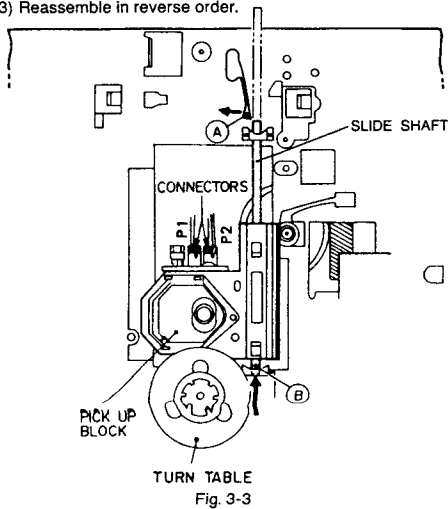

Fig. 3-3

3-3. REPLACEMENT OF THE SPINDLE MOTOR

- 1) Turn the ④ GEAR HOLDER LEVER counter-clockwise (Fig. 3-4), then pull out the SLIDE GEAR.
- 2) Keep the PICK UP BLOCK away from the SPINDLE MOTOR (↑ direction as shown in Fig. 3-5).
- 3) Remove the two SPINDLE MOTOR fixation screws through the hole on the TURN TABLE (Fig. 3-5), then remove the SPINDLE MOTOR.
- 4) Reassemble in reverse order.

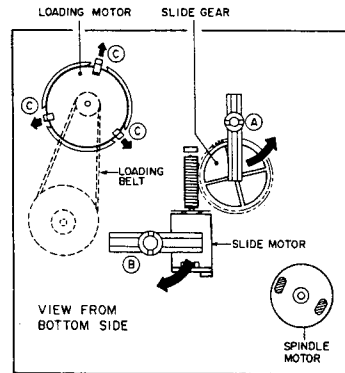

Fig. 3-4

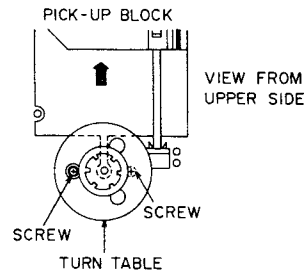

Fig. 3-5

3-4. REPLACEMENT OF THE LOADING MOTOR

- 1) Remove the LOADING BELT, then remove the LOADING MOTOR while releasing the ③ hooks (Fig. 3-4).
- 2) To reassemble, push in the LOADING MOTOR and replace the LOADING BELT.

3-5. REPLACEMENT OF THE SLIDE MOTOR

- 1) Turn the ⑥ SLIDE MOTOR HOLD LEVER (Fig. 3-4) clockwise, then pull out the SLIDE MOTOR.
- 2) Reassemble in reverse order.

IV. ELECTRICAL ADJUSTMENT

[ABOUT THE TEST MODE]

- 1) This test mode is used for adjustment or checking.
- 2) How to engage the TEST mode.
While pushing the ◀ and ▶ buttons simultaneously on the front panel, connect the flat connection cable to the amplifier.
- 3) Push the ⏸ button to advance the TEST mode number. When the TEST mode number is initialized, push the □ button.
- 4) Disconnect the flat connection cable from the amplifier to exit from the TEST mode.

STEP	ADJUSTMENT ITEM
1.	Test disc
2.	Mode or TEST mode number
3.	Test point and ADJ. part
4.	•Remarks
	*Result

Test Point Adjustment Part

TEST mode number and functions

TEST mode number	Functions
1	• Indicates that unit is engaged in the TEST mode.
12	• Indicates the end of FOCUS SEARCH.
123	• Engaged in the CLV-S mode. Tracking servo gain is set to the same setting as "JUMP" mode.
1234	• Tracking servo is on.
12345	• Unit is engaged in the normal play mode without anti shock function.
123456	• Unit is engaged in the normal play mode.
1234567	• Tray is open
12345678	• Tray is close

2 E-F BALANCE

1. Test disc 5A (AT-751330)
2. TEST mode 3
3. TP (TE), VR2
4. •Connect an oscilloscope to TP (TE).

*A = B



4 FOCUS OFF-SET

1. Test disc 5A (AT-751330)
2. Test mode 1 and 2
3. TP (FE), VR5
4. •Connect a digital DC voltmeter to TP (FE) and check the voltage A in the test mode 2, then press STOP button and adjust VR5 so that the reading voltage B on the digital DC voltmeter is same as voltage A.

*Voltage A = Voltage B

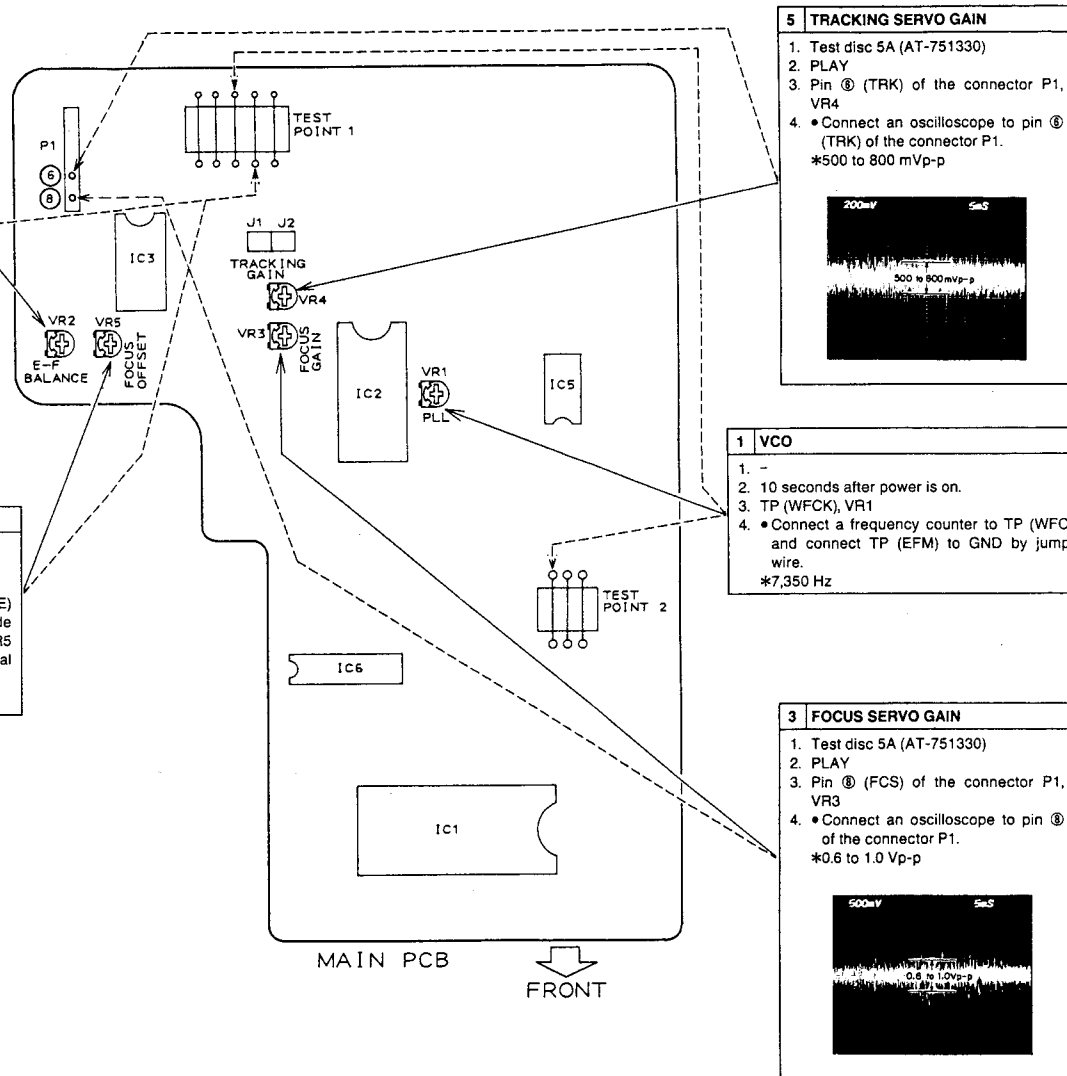

5 TRACKING SERVO GAIN

1. Test disc 5A (AT-751330)
2. PLAY
3. Pin ③ (TRK) of the connector P1, VR4
4. •Connect an oscilloscope to pin ③ (TRK) of the connector P1.

*500 to 800 mVp-p

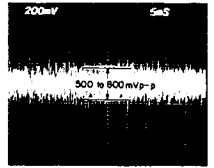

1 VCO

1. -
2. 10 seconds after power is on.
3. TP (WFCK), VR1
4. •Connect a frequency counter to TP (WFCK) and connect TP (EFM) to GND by jumper wire.

*7,350 Hz

3 FOCUS SERVO GAIN

1. Test disc 5A (AT-751330)
2. PLAY
3. Pin ③ (FCS) of the connector P1, VR3
4. •Connect an oscilloscope to pin ③ of the connector P1.

*0.6 to 1.0 Vp-p



V. PARTS LIST

ATTENTION

- When placing an order for parts, be sure to list Part No., Model No. and the description of eachpart. Otherwise, the non-delivery of the part or the delivery of a wrong part may result.
- Please make sure that Part No. is correct when ordering. If not, a part different from the one you ordered may be delivered.
- Since the parts shown in Parts List of Preliminary Service Manual may have been the subject of changes, please use this Parts List for all future reference.

HOW TO USE THIS PARTS LIST

- This Parts List lists those parts which are considered necessary for repairs. Other common parts, such as resistors and capacitors, are listed in the "Common List for Service Parts" from which these parts should be selected and stocked.
- The Recommended Spare Parts List shows those parts in the Parts List which are considered particularly important for service.
- Parts not shown in the Parts List and "Common List for Service Parts" will not in principle be supplied.
- How to read the Parts List.

a) Mechanism Block

2. HEAD BASE BLOCK

Ref.No.	Part No.	Description
1	BH-T2023A320A	HEAD BASE BLOCK
2	HP-H2206A010A	HEAD R/P PR4-8FU C
3	ZS-477876	PAN20×03STL CMT
4	ZS-536488	BID20×08STL CMT
5	ZG-402895	SP CS ANGLE ADJUST

SP (Service Parts) Classification

This number corresponds with the individual parts index number in that figure.

b) PC Board

6. MAIN PC BOARD

Ref.No.	Part No.	Description
IC1	EI-324536	IC HD14049BP
IC2	EI-336801	IC MB8841-564M
C1A	EC-338399	C MMY V 223M 250AC [U,E,B,S]
C1B	EC-350949	C MMY V 223M 250DC [J]
C1C	EC-338397	C MMY V 223M 125AC [C,A]
X1	EI-318384	OSC X'TAL NC-18C

Symbols for primary destination

[A]: AAL (U.S.A) [S]: SAA (Australia)
 [B]: BEAB (England) [U]: U/T (Universal Area)
 [C]: CSA (Canada)
 [E]: CEE (Europe) [V]: VDE (W. Germany)
 [J]: JPN (Japan) [Y]: Custom Version

SP (Service Parts) Classification

These reference symbols correspond with component symbols in the Schematic Diagrams.

The available PC Board Blocks are listed separately.

WARNING

△ (*) INDICATES SAFETY CRITICAL COMPONENTS. FOR CONTINUED SAFETY, REPLACE SAFETY CRITICAL COMPONENTS ONLY WITH MANUFACTURE'S RECOMMENDED PARTS.

AVERTISSEMENT

△ (*) IL INDIQUE LES COMPOSANTS CRITIQUES DE SÉCURITÉ. POUR MAINTENIR LE DEGRÉ DE SÉCURITÉ DE L'APPAREIL, NE REMPLACER QUE DES PIÈCES RECOMMANDÉES PAR LE FABRICANT.

1. RECOMMENDED SPARE PARTS

We suggest you to stock the following Recommended Spare Part items listed below since they can cover most of the routine service.

Ref.No.	Part No.	Description
1	BM-392868M	SG MOTOR LOADING PART (2)
2	BM-392869M	SG MOTOR SLIDE PART
3	BM-392867M	SG MOTOR SPINDLE PART
4	*BO-394728J	PICK UP KSS-210A
5	ED-394416J	D LED SLV-31VT3F RED
6	ED-307572	D SILICON H 1SS131
7	*ED-389840J	D SILICON 1SR139-100HS F10
8	ED-403743J	D ZENER H HZS6B3
9	ED-387783J	D ZENER H HZS6C3L F05
10	ED-387820J	D ZENER H HZS9A2L F05
11	EI-389264J	IC BA6209N
12	EI-390112J	IC CXA1081S
13	EI-390120J	IC CXA1082BS
14	EI-368610	IC CXD1135Q
15	EI-382251J	IC LC3517BS-15
16	EI-405338J	IC UPD75212ACW FXA2CD2-285
17	EI-390149J	OSC CE CST4.23MGW 4.230MHZ
18	EI-381139J	OSC X'TAL HC-49/U 16934.400KHZ
19	EJ-394490J	SOCKET OPTICAL GP1F32T
20	EM-389466J	IND FL FIP8CYM7 CHARACTER
21	ES-368603	SW LEAF MSW-1585
22	ES-393376J	SW LEAF SPPB22 01-1
23	ES-394818J	SW TACT SOR-123HS T05
24	ET-360399	TR DTC114TS
25	ET-354365	TR DTC114YS
26	ET-354371	TR DTC124ES
27	ET-373392	TR DTC124XS
28	ET-353899	TR 2SA1317 S.T.U
29	ET-394555J	TR 2SA1515 Q,R
30	ET-394495J	TR 2SA934 Q,R
31	ET-394919J	TR 2SB1329 Q,R T05
32	ET-394494J	TR 2SC2060 Q,R F05
33	ET-397160J	TR 2SC3330 R,S,T,U,V
34	ET-394554J	TR 2SD1379
35	ET-394917J	TR 2SD2005 Q,R T05
36	ET-394916J	TR 2SD2037 E,F T05
37	EW-394419J	WIRE ASSY P2059 12P
38	MB-368590J1	BELT LOADING

2. CD MECHANISM

Ref.No.	Part No.	Description
1	MA-380689M	CHASSIS MECHA OUTSERT PART
2	*BO-394728J	PICK UP KSS-210A
5	MS-368348	SHAFT
6	BM-392867M	SG MOTOR SPINDLE PART
7	ZS-367463	PAN20X025STL CMT
8	MB-368350	CUSHION RUBBER
9	BM-392868M	SG MOTOR LOADING PART (2)
10	MZ-368349M	GEAR WORM WHEEL
11	BM-392869M	SG MOTOR SLIDE PART
12	ES-368603	SW LEAF MSW-1585
13	ES-393376J	SW LEAF SPPB22 01-1
14	ZS-536488	BID20X08STL CMT
15	ZS-343082	PT BR26X08STL CMT
16	MR-394361M	PULLEY GEAR(B)
17	MB-368590J1	BELT LOADING
18	MZ-388217M	CAM GEAR LOADING
19	ZS-365391	PT BR30X08STL CMT C080
20	MZ-368347M	CLAMPER
21	SZ-374136M	HOLDER CLAMPER
22	ZG-368591J1	SP PUSH CLAMP
23	SC-382692M2	DISK TRAY S PART
24	MZ-382666M	HOLDER DISC S-(R)
25	MZ-382687M	HOLDER DISC S-(L)
26	ZG-368592	SP PULL DISK HOLD
27	MB-377975	STOPPER RUBBER
30	MZ-378828J	ANGLE TRAY
31	ZS-432843	PAN26X04STL CMT

NOTE:

Parts will not be supplied if they are not listed in the parts list, even if they appear on the assembling illustrations with reference No.

CD MECHANISM

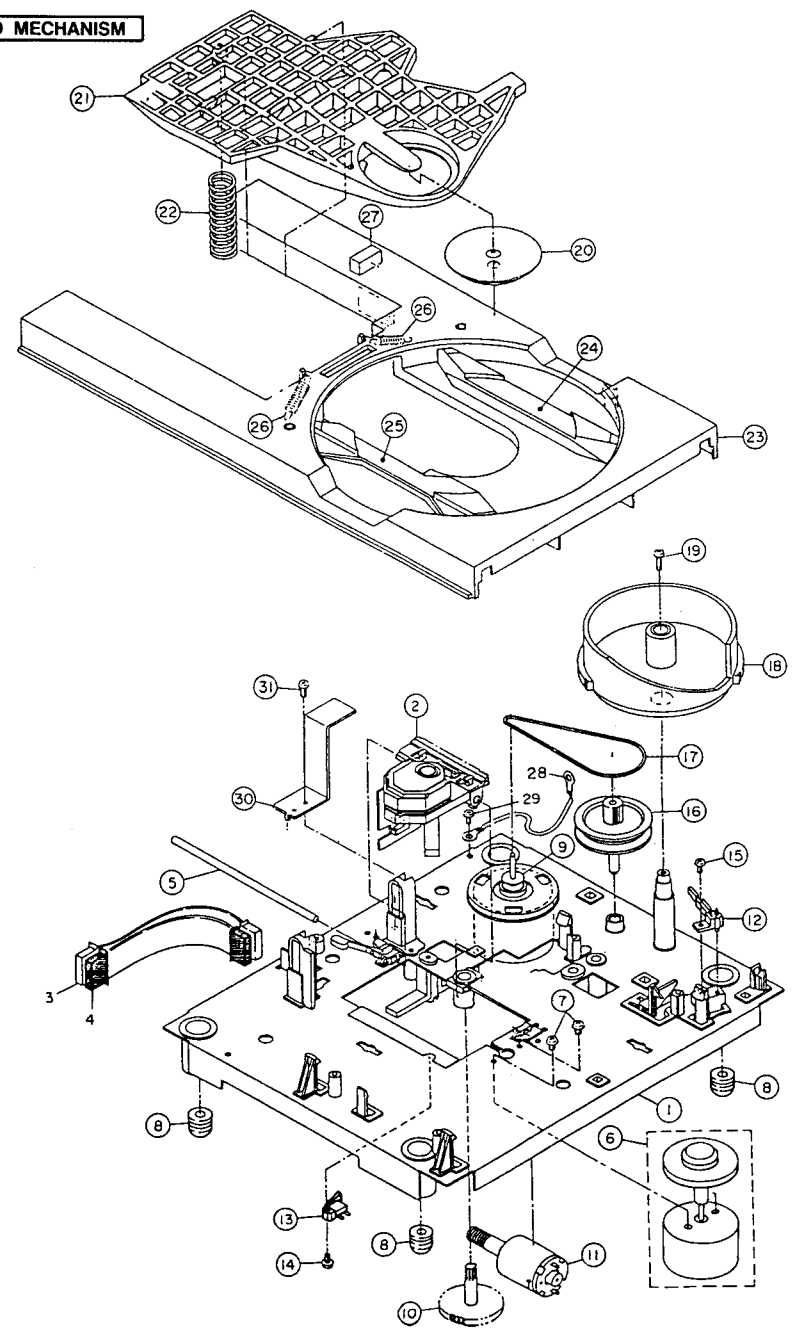

PARTS LIST

3. P.C BOARD

Ref.No.	Part No.	Description
1	BB-P2060T020A	ML PCI(8) MAIN BLK CD-M630/ML

PC (#) MAIN BLK CONSISTS OF FOLLOWING P.C BOARD.

- MAIN P.C BOARD
- FRONT P.C BOARD
- LED P.C BOARD

4. MAIN P.C BOARD

Ref.No.	Part No.	Description
D1	*ED-389840J	D SILICON 1SR139-100HS F10
D2	*ED-389840J	D SILICON 1SR139-100HS F10
D3	*ED-389840J	D SILICON 1SR139-100HS F10
D4	*ED-389840J	D SILICON 1SR139-100HS F10
D5	ED-387783J	D ZENER H HZ56C3L F05
D6	ED-387783J	D ZENER H HZ56C3L F05
D7	ED-403743J	D ZENER H HZ56B3
D8	ED-387820J	D ZENER H HZ59A2L F05
D9	ED-307572	D SILICON H 1SS131
D10	ED-307572	D SILICON H 1SS131
D13	ED-307572	D SILICON H 1SS131
D14	ED-387783J	D ZENER H HZ56C3L F05
D15	ED-307572	D SILICON H 1SS131
IB1	EH-394546J	COMP R RKC9DS 223J
IC1	EL-405338J	IC UPD75212ACW FXA2CD2-285
IC2	EL-390120J	IC CXA1082B5
IC3	EL-390112J	IC CXA1081S
IC4	EL-368610	IC CXD1135Q
IC5	EL-382251J	IC LC3517BS-15
IC6	EL-389264J	IC BA6209N
J4	EJ-394490J	SOCKET OPTICAL GP1F32T
R50	ER-382474J	R OMF H S10 FS 1/2W 1R2J
TR1	ET-394554J	TR 2SD137B
TR2	ET-394555J	TR 2SA1516 Q,R
TR4	ET-353899	TR 2SA1317 S,T,U
TR8	ET-353899	TR 2SA1317 S,T,U
TR9	ET-397160J	TR 2SC3330 R,S,T,U,V
TR10	ET-394916J	TR 2SD2037 E,F T05
TR11	ET-394495J	TR 2SA934 Q,R
TR12	ET-394916J	TR 2SD2037 E,F T05
TR13	ET-394919J	TR 2SB1329 Q,R T05
TR14	ET-394494J	TR 2SC2060 Q,R F05
TR15	ET-394495J	TR 2SA934 Q,R
TR16	ET-394917J	TR 2SD2005 Q,R T05
TR17	ET-394919J	TR 2SB1329 Q,R T05
TR18	ET-397160J	TR 2SC3330 R,S,T,U,V
TR19	ET-397160J	TR 2SC3330 R,S,T,U,V
TR20	ET-397160J	TR 2SC3330 R,S,T,U,V
TR21	ET-397160J	TR 2SC3330 R,S,T,U,V
TR22	ET-373392	TR DTC124XS
TR23	ET-373392	TR DTC124XS
TR24	ET-354371	TR DTC124ES
TR25	ET-360399	TR DTC114TS
TR26	ET-360399	TR DTC114TS
TR27	ET-360399	TR DTC114TS
TR28	ET-373392	TR DTC124XS
TR29	ET-373392	TR DTC124XS
TR30	ET-373392	TR DTC124XS
TR31	ET-373392	TR DTC124XS
TR32	ET-354365	TR DTC114YS
VR1	EV-393741J	R S-FIX H T05 RH064JC 0.3W 102
VR2	EV-390872J1	R S-FIX H T05 RH0638C 0.1W 223
VR3	EV-390872J1	R S-FIX H T05 RH0638C 0.1W 223
VR4	EV-390872J1	R S-FIX H T05 RH0638C 0.1W 223
VR5	EV-390872J11	R S-FIX H T05 RH0638C 0.1W 472
VR5	EV-391139J	OSC XTAL HC-49/U 16934.400KHZ
XD	EJ-3900180J	OSC DE DST4.23MQUW 4.230MHZ

5. FRONT P.C BOARD

Ref.No.	Part No.	Description
D101	ED-307572	D SILICON H 1SS131
D102	ED-307572	D SILICON H 1SS131
D103	ED-307572	D SILICON H 1SS131
IN1	EM-389466J	IND FL FIP8CYM7 CHARACTER
SW1	ES-394818J	SW TACT SOR-123HS T05
SW2	ES-394818J	SW TACT SOR-123HS T05
SW3	ES-394818J	SW TACT SOR-123HS T05
SW4	ES-394818J	SW TACT SOR-123HS T05
SW5	ES-394818J	SW TACT SOR-123HS T05
SW6	ES-394818J	SW TACT SOR-123HS T05

6. LED P.C BOARD

Ref.No.	Part No.	Description
D201	ED-394416J	D LED SLV-31VT3F RED
D202	ED-394416J	D LED SLV-31VT3F RED
D203	ED-394416J	D LED SLV-31VT3F RED
D204	ED-394416J	D LED SLV-31VT3F RED

7. FINAL ASSEMBLY

Ref.No.	Part No.	Description
1	SP-401752M	PANEL FRONT
2	SA-394136M	CUSHION FOOT
3	SZ-401762M	RING FOOT
5	SE-402579M	FILTER FLD(CD)-B
6	SE-401761M	WINDOW
8	SK-401763M	BUTTON OPERATION
9	SA-394127M1	FOOT REAR
10-A	SP-402644M	PANEL REAR CD-M630(U) [U]
10-B	SP-402643M	PANEL REAR CD-M630(E) [E,V]
11	EW-394419J	WIRE ASSY P2059 12P
12	SE-394119M	LENS OPTICAL
13	SE-394121M	REFLECTOR OPTICAL
14	SP-401764M	PANEL TRAY
15	SZ-401759M	WINDOW TRAY
16	SP-394096M	COVER UPPER AT
17	ZS-387983J	ST BID30X08STL BNI EARTH LOCK
18	ZS-331182	BT BID30X08STL BNI
19	ZS-394114M	SCREW GRADUATED
20	ZS-378163	SCREW GRADUATED

NOTE:

Parts will not be supplied if they are not listed in the parts list, even if they appear on the assembling illustrations with reference No.

8. ACCESSORY

Ref.No.	Part No.	Description
1	AX-385911J	CORD P2187-60A

FINAL ASSEMBLY

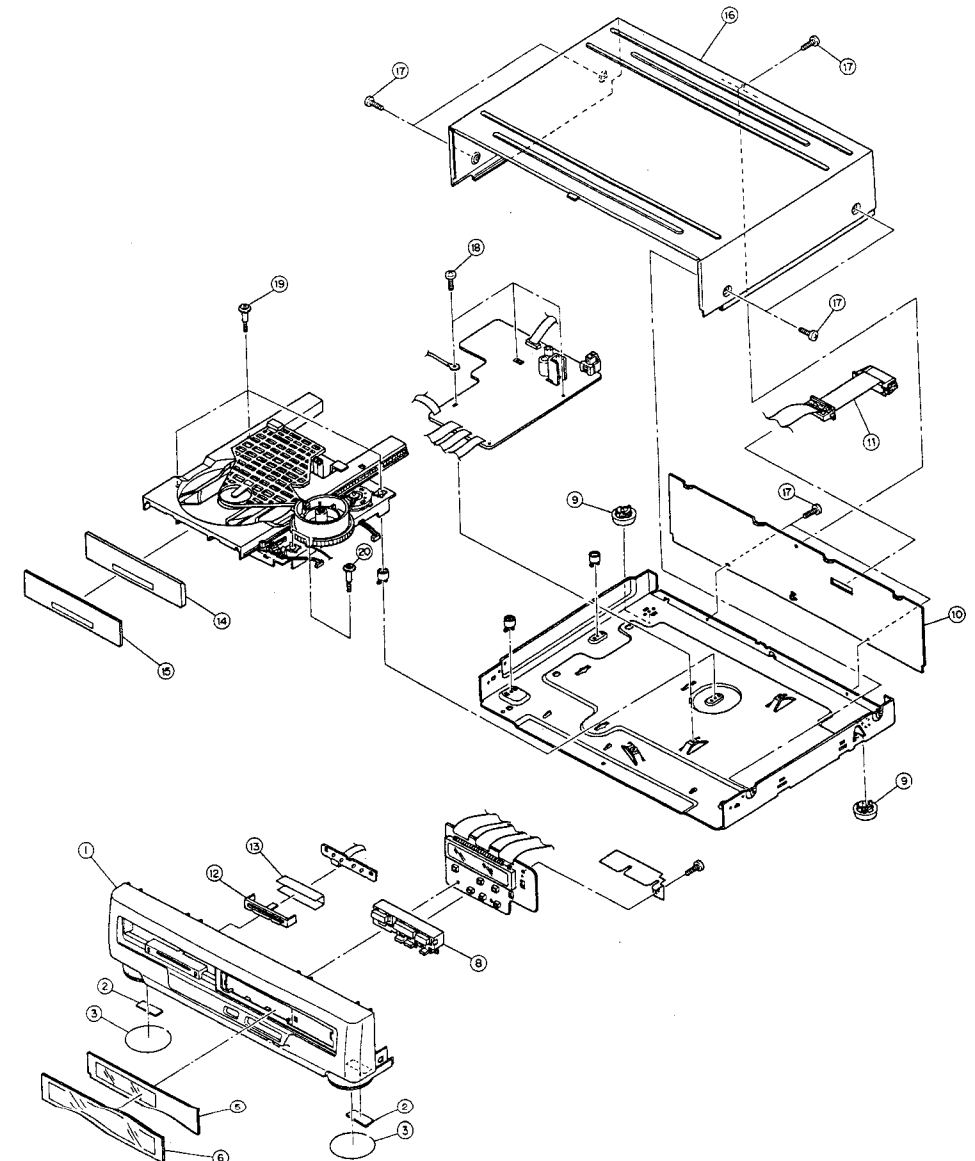

AKAI

MODEL **CD-M630**

SCHEMATIC DIAGRAMS AND PC BOARDS

TABLE OF CONTENTS

1. BLOCK DIAGRAM	3
2. SCHEMATIC DIAGRAM	4
3. MAIN AND OTHER PC BOARDS	5
4. INFORMATION OF ICs	6

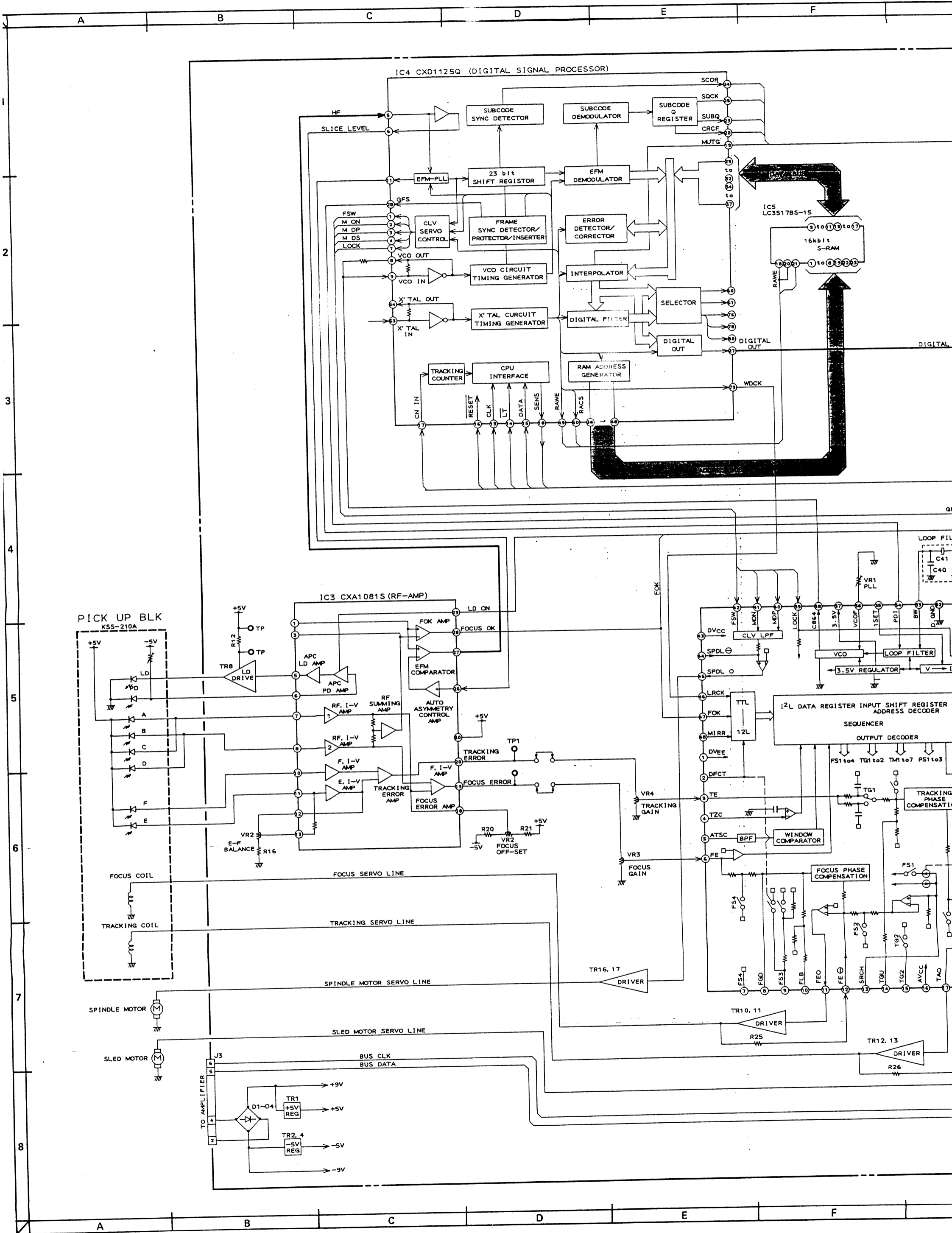

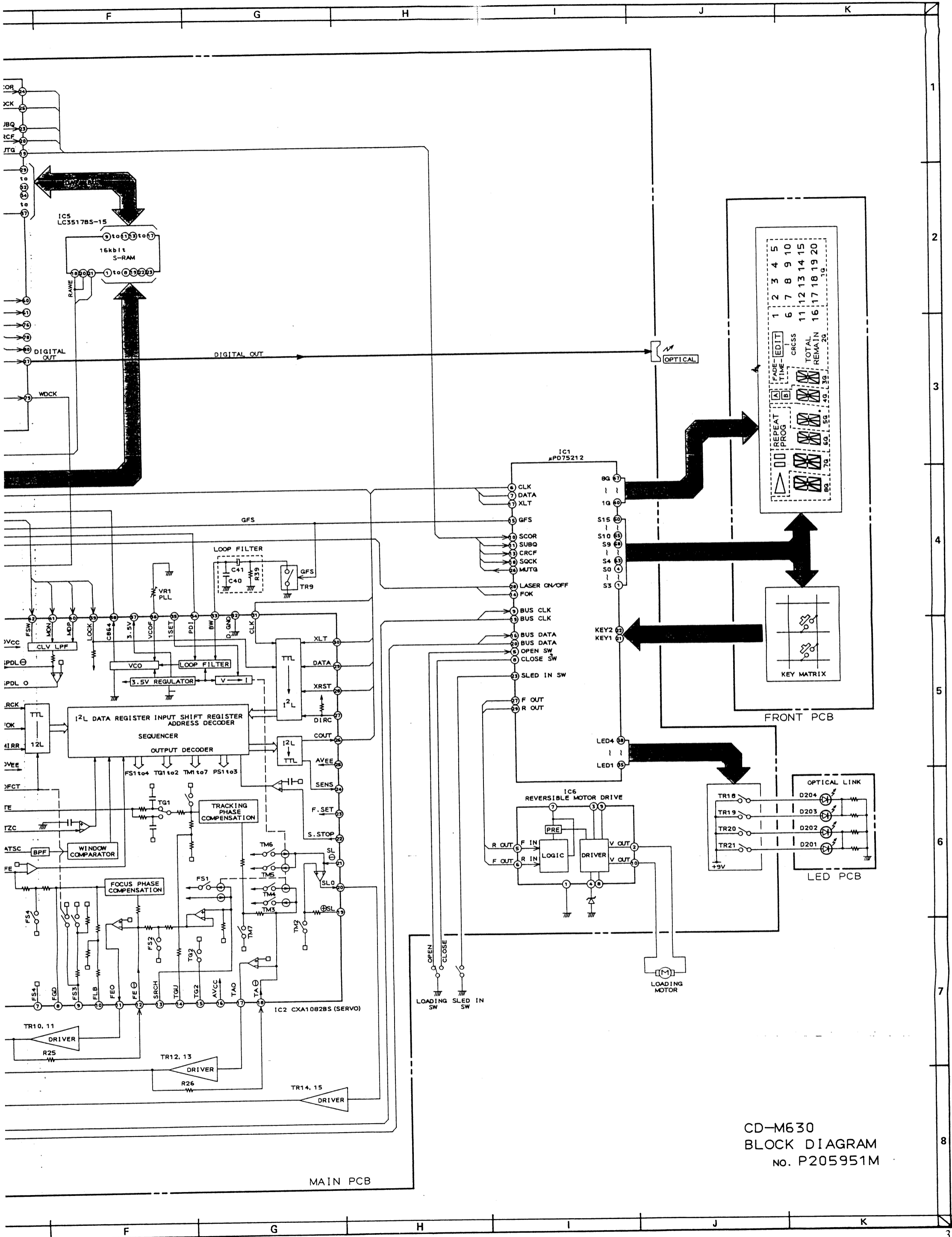

CD-M630
BLOCK DIAGRAM
no. P205951M

1
2
3
4
5
6
7
8

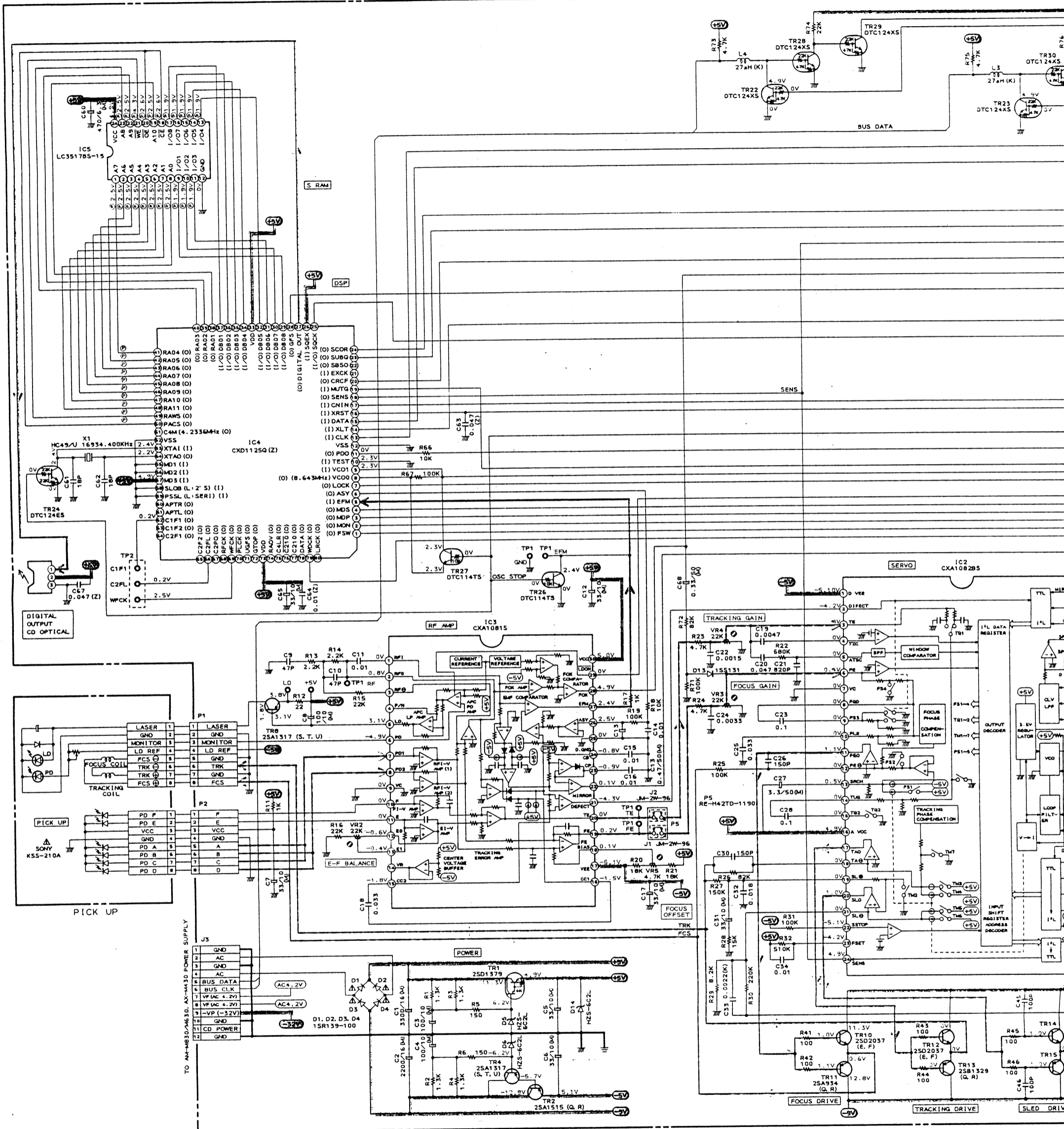

△ MAIN PCB P2059A501A

- (POWER SUPPLY) LINE
- SIGNAL LINE
- FOCUS SERVO LINE
- TRACKING SERVO LINE
- SPINDLE MOTOR SERVO LINE
- SLIDE MOTOR SERVO LINE

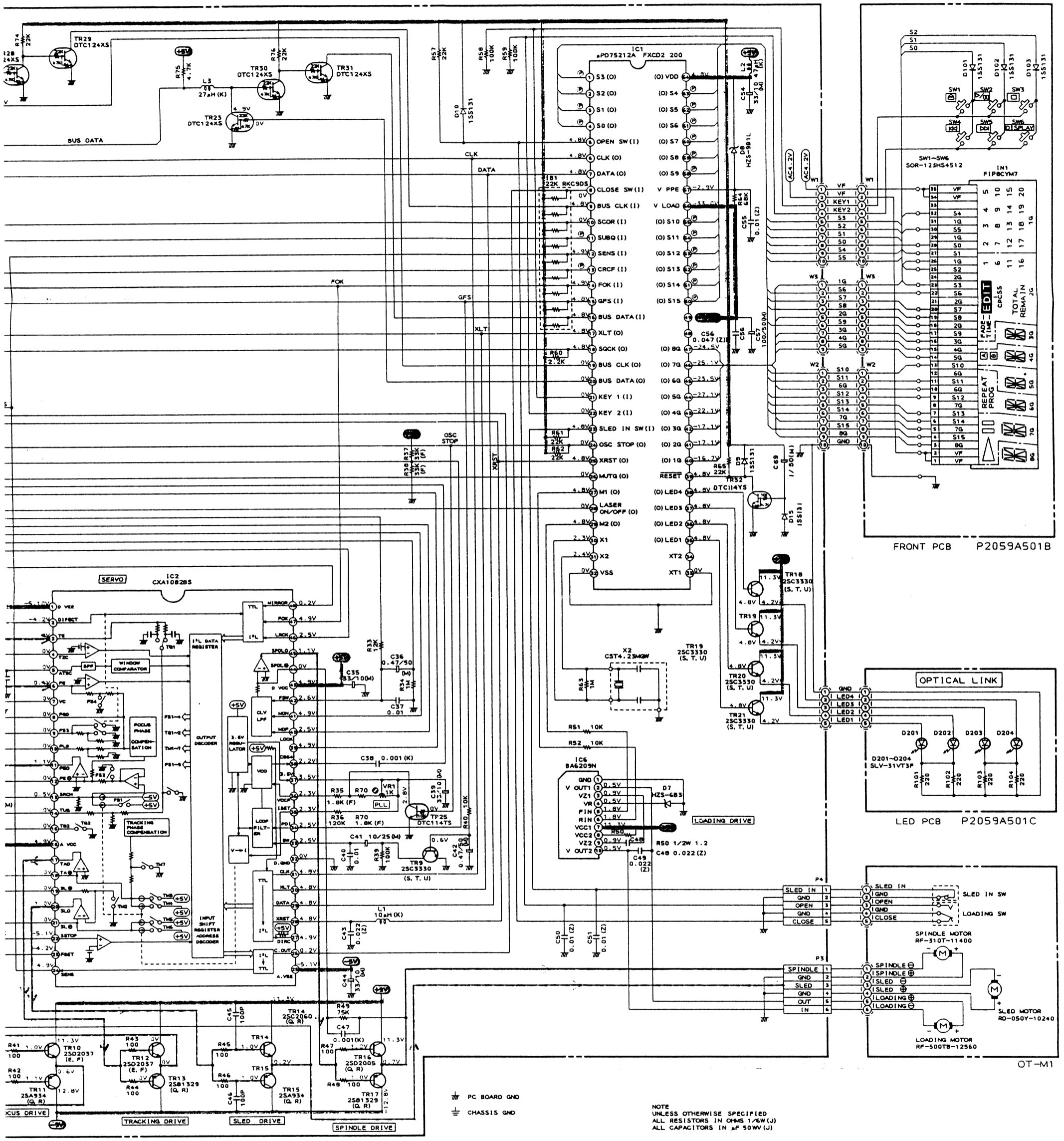

- - - - - :B (POWER SUPPLY) LINE
 ———— : SIGNAL LINE
 - · - · - : FOCUS SERVO LINE
 - · - · - : TRACKING SERVO LINE
 - · - · - : SPINDLE MOTOR SERVO LINE
 - · - · - : SLIDE MOTOR SERVO LINE

INDICATED VOLTAGES ARE MEASURED AT PLAY MODE.

WARNING: Δ AND ∇ INDICATE SAFETY CRITICAL COMPONENTS FOR CONTINUED SAFETY. REPLACE SAFETY CRITICAL COMPONENTS ONLY WITH MANUFACTURER'S RECOMMENDED PARTS.
 AVERTISSEMENT: Δ ET ∇ ILS INDIQUENT LES COMPOSANTS CRITIQUES DE SÉCURITÉ. POUR MAINTENIR LE DEGRÉ DE SÉCURITÉ DE L'APPAREIL, NE REMPLACER QUE DES PIÈCES RECOMMANDÉES PAR LE FABRICANT.

CD-M630
SCHEMATIC DIAGRAM
 No. P206001M

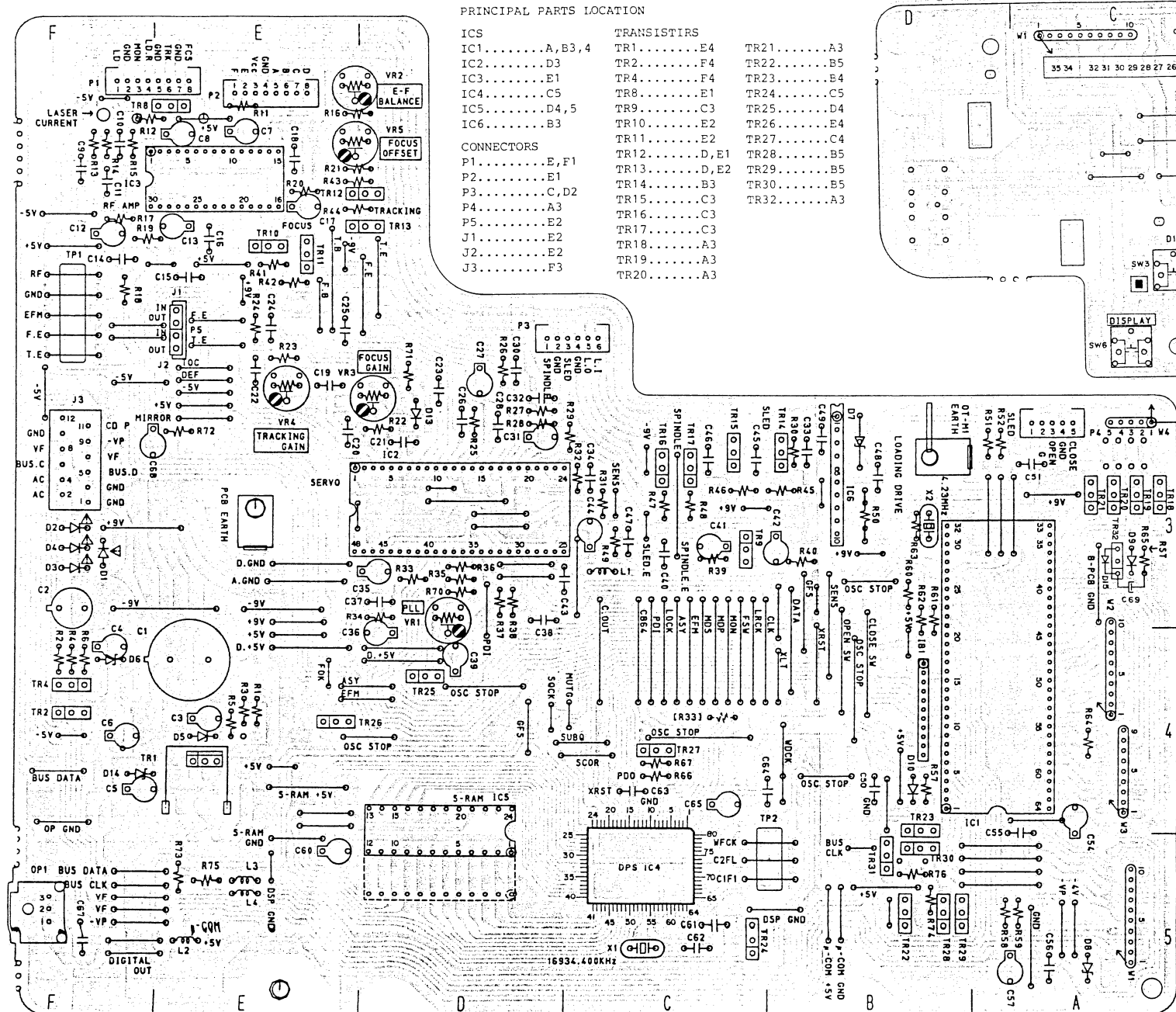

PRINCIPAL PARTS LOCATION

ICS	TRANSISTORS	
IC1.....A,B3,4	TR1.....E4	TR21.....A3
IC2.....D3	TR2.....F4	TR22.....B5
IC3.....E1	TR4.....F4	TR23.....B4
IC4.....C5	TR8.....E1	TR24.....C5
IC5.....D4,5	TR9.....C3	TR25.....D4
IC6.....B3	TR10.....E2	TR26.....E4
	TR11.....E2	TR27.....C4
CONNECTORS	TR12.....D,E1	TR28.....B5
P1.....E,F1	TR13.....D,E2	TR29.....B5
P2.....E1	TR14.....B3	TR30.....E5
P3.....C,D2	TR15.....C3	TR32.....A3
P4.....A3	TR16.....C3	
P5.....E2	TR17.....C3	
J1.....E2	TR18.....A3	
J2.....E2	TR19.....A3	
J3.....F3	TR20.....A3	

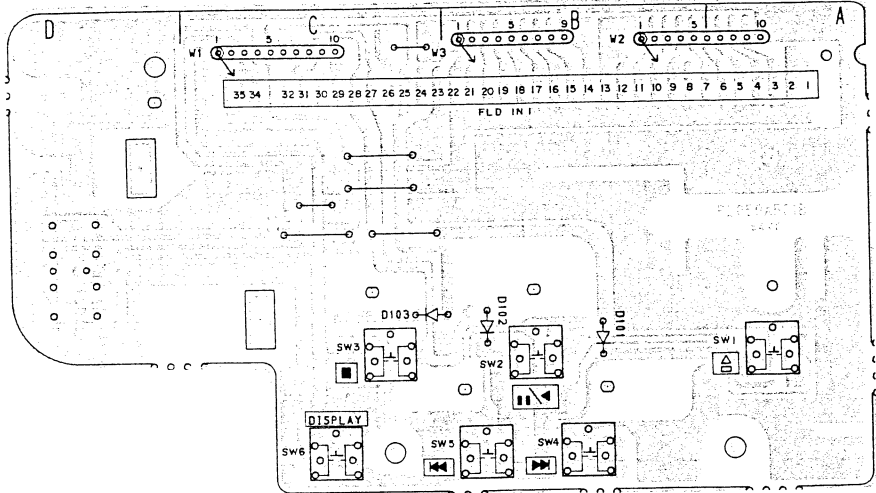

FRONT PCB P2059A501B

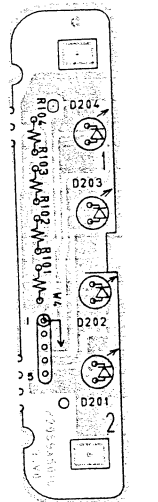

LED PCB P2059A501C

WARNING ⚠ INDICATES SAFETY CRITICAL COMPONENTS FOR CONTINUED SAFETY. REPLACE SAFETY CRITICAL COMPONENTS ONLY WITH MANUFACTURER'S RECOMMENDED PARTS.
 AVERTISSEMENT ⚠ IL INDIQUE LES COMPOSANTS CRITIQUES DE SÉCURITÉ. POUR MAINTENIR LE DEGRÉ DE SÉCURITÉ DE L'APPAREIL, NE REMPLACER QUE DES PIÈCES RECOMMANDÉES PAR LE FABRICANT.

MAIN PCB P2059A501A

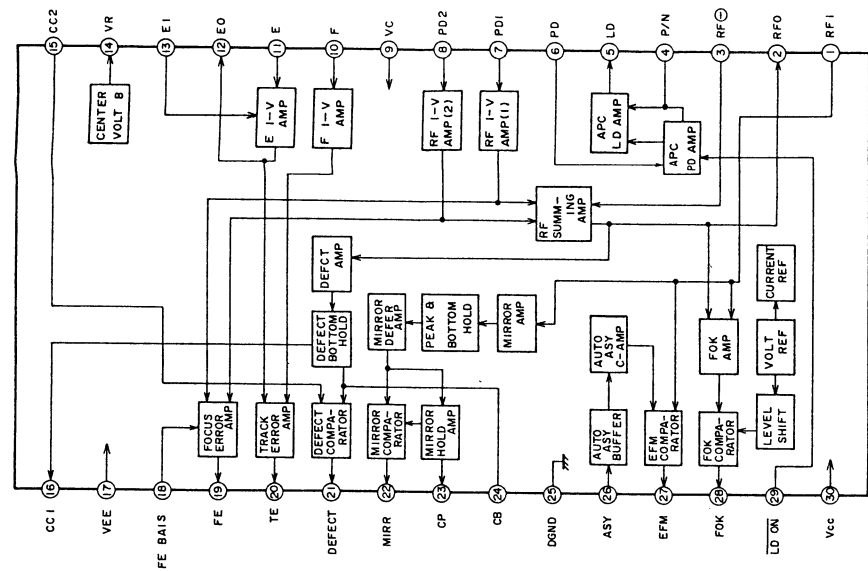

PIN NO.	SYMBOL	I/O	FUNCTION
1	RF1	I	RF SIGNAL FROM SUMMING AMP
2	RF0	O	RF SIGNAL OUT (EYE PATTERN CHECK POINT)
3	RF \ominus	I	FEED BACK TO SUMMING AMP
4	P/N	-	NC
5	LD	O	AUTO POWER CONTROL OUT (TO LASER DIODE)
6	PD	I	AUTO POWER CONTROL IN (FROM PILOT DIODE)
7	PD1	I	A+C SIGNAL RF I-V AMP IN
8	PD2	I	B+D SIGNAL RF I-V AMP IN
9	VC	-	GND
10	F	I	TRACKING DIODE SIGNAL RF I-V AMP IN (F)
11	E	I	TRACKING DIODE SIGNAL RF I-V AMP IN (E)
12	E0	O	RF I-V AMP (E) OUT
13	E1	I	FEED BACK TO RF I-V AMP (E)
14	VR	-	NC
15	CC2	I	DEFECT BOTTOM HOLD IN
16	CC1	O	DEFECT BOTTOM HOLD OUT
17	VEE	-	-B
18	F·EBIAS	I	FOCUS OFF-SET VOLTAGE IN
19	FE	O	FOCUS ERROR OUT
20	TE	O	TRACKING ERROR OUT
21	DEFECT	O	DEFECT COMPALATOR OUT
22	MIRR	O	MIRROR COMPALATOR OUT
23	CP	I	CONNECT MIRROR HOLD CONDENSER
24	CB	I	CONNECT BOTTOM HOLD CONDENSER
25	DGND	-	GND
26	ASY	I	AUTO ASYMMETRY SIGNAL IN
27	EFM	O	EFM COMPALATOR OUT
28	FOK	O	FOCUS OK COMPALATOR OUT
29	LDON	I	LASER DIODE ON/OFF CONTROL IN
30	VCC	-	+B

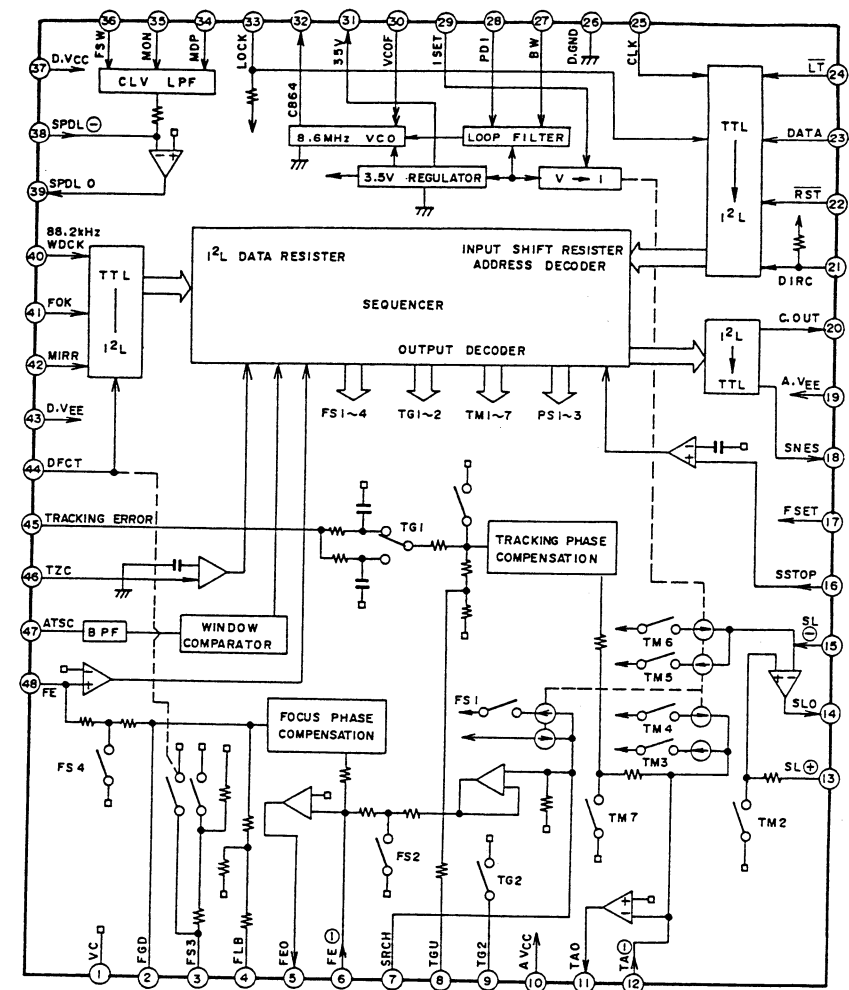

PIN NO.	SYMBOL	I/O	DESCRIPTION
1	VC	-	GND (0V)
2	FGD	-	Connect condenser for Focus servo gain control.
3	FS3	-	Focus servo gain select.
4	FLB	-	Connect condenser for Focus servo correction.
5	FE0	O	Focus drive output.
6	FE \ominus	I	FOCUS AMP. Inverting input.
7	SRCH	-	Connect condenser for Focus search wave.
8	TGU	-	Connect condenser for Tracking gain select.
9	TG2	-	Connect condenser for Tracking gain select.

PIN NO.	SYMBOL	I/O	DESCRIPTION
10	A.VCC	—	+5V
11	TA0	O	Tracking drive output.
12	TA ⊖	I	Tracking AMP. Inverting input.
13	SL ⊕	I	Slide motor non-inverting input
14	SLO	O	Slide motor drive output.
15	SL ⊖	I	Slide AMP. inverting input.
16	SSTOP	I	Not use (Holed "H" level).
17	FSET	I	Focus, Tracking compensation and CLV. LPF set up.
18	SENS	O	FZC. AS. TZC. SSTOP and BUSY output.
19	A. VEE	—	-5V.
20	C.OUT	O	Track count signal output.
21	DIRC	—	Not used
22	RST	I	RESET Input.
23	DATA	I	Data signal input from CPU.
24	LT	I	Lutch signal input from CPU.
25	CLK	I	Clock signal input from CPU.
26	D.GND	—	GND (0V).
27	BW	I	Connect condenser for Loop filter.
28	PDI	I	PDO signal from IC3 CXD1135Q (Pin 11).
29	ISET	I	Focus search, Track jump and slide kick current input.
30	VCOF	I	Connect register for VCO frequency.
31	3.5V	O	+3.5V REG. output.
32	C864	O	8.64 MHz VCO output.
33	LOCK	I	LOCK signal from IC3 CXD1135Q (Pin 7)
34	MDP	I	MDP signal from IC3 CXD1135Q (Pin 3)
35	MON	I	MON signal from IC3 CXD1135Q (Pin 2)
36	FSW	I	Connect condenser for CLV servo error signal LPF.
37	DVcc	—	+5V
38	SPDL ⊖	I	Spindle drive AMP. inverting input.
39	SPDLO	I	Spindle drive output.
40	WDCK	I	Auto sequence clock signal input (88.2 kHz)
41	FOK	I	Focus OK signal input.
42	MIRR	I	MIRR signal input.
43	DVEE	—	-5V
44	DFCT	I	Defect signal input "H" active.
45	TE	I	Tracking error signal input.
46	TZC	I	Tracking zero cross comparator input.
47	ATSC	I	ATSC detect window comparator input.
48	FE	I	Focus error signal input.

CXD1125Q (DIGITAL SIGNAL PROCESSOR)

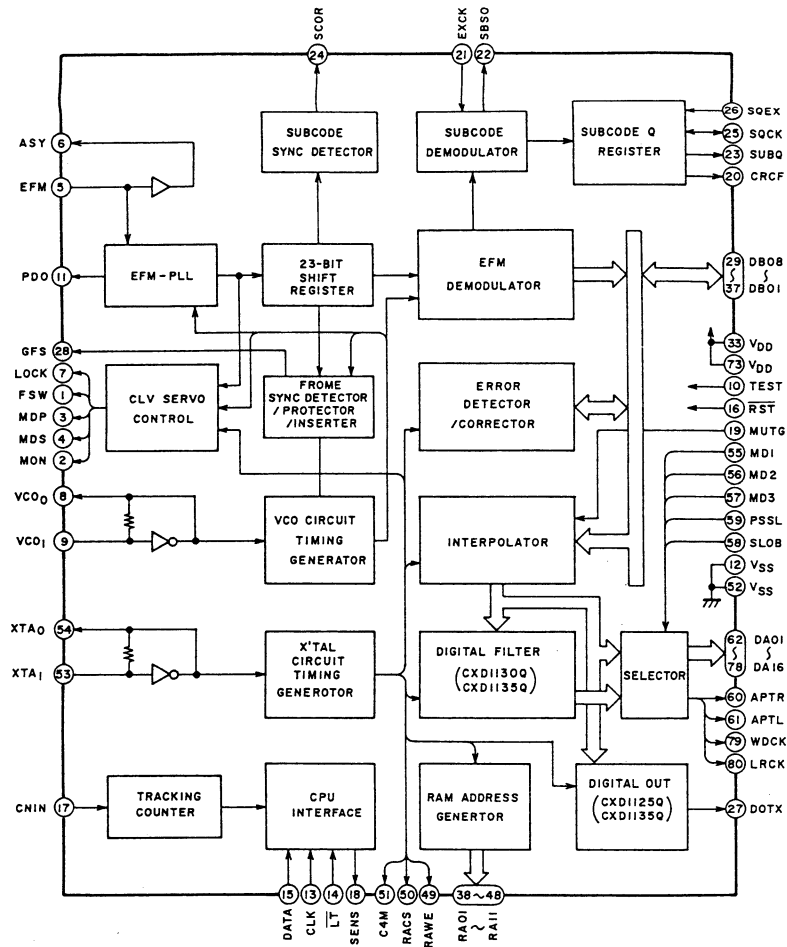

CXD1125Q (DIGITAL SIGNAL PROCESSOR)

No. "	Symbol	I/O	Description
1	FSW	O	Spindle motor filter switching control
2	MON	O	Spindle motor ON/OFF control
3	MPD	O	Spindle motor speed and phase control
4	MDS	O	Spindle motor speed control
5	EFM	I	EFM signal input
6	ASY	O	EFM signal slice level control
7	LOCK	O	Slide motor over reach guard signal output
8	VCOO	O	VCO output f=8.6436 MHz
9	VCOI	I	VCO input
10	TEST	I	OV (GND)
11	PDO	O	Phase comp.output
12	VSS	—	GND (OV)
13	CLK	I	Clock signal from CPU
14	LT	I	Lutch signal from CPU
15	DATA	I	Serial data from CPU
16	RST	I	RESET input "L" reset
17	CNIN	I	Tracking pulse input (5V)
18	SENS	O	Output of CPU interface
19	MUTG	I	Mute control signal input
20	CRCF	O	CRC check output of the subcode Q "L" detect error
21	EXCK	I	NOT USE
22	SBSO	O	NOT USE
23	SUBQ	O	Subcode Q output
24	SCOR	O	Subcode sync detection output
25	SQCK	I/O	Clock signal for subcode Q
26	SQEX	I	Select input of CQCK (+5V)
27	DOTX	O	Digital output
28	GFS	O	"H" frame sync lock "L" frame sync unlock
29	DB08	I/O	Data 8 (MSB) Data Bus line for the EXT.RAM (LC3517BS-15)
30	DB07	I/O	Data 7 Data bus line for the EXT.RAM (LC3517BS-15)
31	DB06	I/O	Data 6 Data Bus line for the EXT.RAM (LC3517BS-15)
32	DB05	I/O	Data 5 Data Bus line for the EXT.RAM (LC3517BS-15)
33	VDD	—	+5V
34	DB04	I/O	Data 4 Data Bus line for the EXT.RAM (LC3517BS-15)
35	DB03	I/O	Data 3 Data bus line for the EXT.RAM (LC3517BS-15)
36	DB02	I/O	Data 2 Data Bus line for the EXT.RAM (LC3517BS-15)
37	DB01	I/O	Data 1 (LSB) Data Bus line for the EXT.RAM (LC3517BS-15)
38	RA01	O	ADDR01 (LSB) Address signal output for the EXT. RAM (LC3517BS-15)
39	RA02	O	ADDR02 Address signal output for the EXT. RAM (LC3517BS-15)
40	RA03	O	ADDR03 Address signal output for the EXT. RAM (LC3517BS-15)

No.	Symbol	I/O	Description
41	RA04	O	ADDR04 Address signal output for the EXT. RAM (LC3517BS-15)
42	RA05	O	ADDR05 Address signal output for the EXT. RAM (LC3517BS-15)
43	RA06	O	ADDR06 Address signal output for the EXT. RAM (LC3517BS-15)
44	RA07	O	ADDR07 Address signal output for the EXT. RAM (LC3517BS-15)
45	RA08	O	ADDR08 Address signal output for the EXT. RAM (LC3517BS-15)
46	RA09	O	ADDR09 Address signal output for the EXT. RAM (LC3517BS-15)
47	RA10	O	ADDR10 Address signal output for the EXT. RAM (LC3517BS-15)
48	RA11	O	ADDR11 (MSB) Address signal output for the EXT. RAM (LC3517BS-15)
49	RAWE	O	Write enable signal output "L" active
50	RACS	O	Chip select signal output "L" active
51	C4M	O	1/4X'tal OSC.output (f=4.2336MHz)
52	Vss	—	GND(0V)
53	XTAI	I	X'tal OSC. input (f=16.9344MHz)
54	XTAO	O	X'tal OSC.output (f=16.9344MHz)
55	MD1	I	Mode select input 1 0V (GND)
56	MD2	I	Mode select input 2 0V (GND)
57	MD3	I	Mode select input 3 0V (GND)
58	SLOB	I	0V (GND)
59	PSSL	I	0V (GND)
60	APTR	O	Aperture correction signal output "H" R-channel
61	APTL	O	Aperture correction signal output "H" L-channel
62	C1F1	O	NOT USE
63	C1F2	O	TP-C1F2
64	C2F1	O	NOT USE
65	C2F2	O	NOT USE
66	C2FL	O	TP-CSFL
67	C2P0	O	NOT USE
68	RFCK	O	NOT USE
69	WFCK	O	TP-WFCK
70	PLCK	O	NOT USE
71	UGFS	O	NOT USE
72	GTOP	O	NOT USE
73	VDD	—	+5V
74	RA0V	O	NOT USE
75	4CLR	O	NOT USE
76	C210	O	C210 INV.C210 (Pin 77) f=2.1168MHz
77	C210	O	NOT USE
78	DATA	O	Data output
79	WDCK	O	Word clock output 88.2kHz strobe
80	LRCK	O	NOT USE (L-ch, R-ch clock output)

LC3517BS-15 (16kBIT RAM)

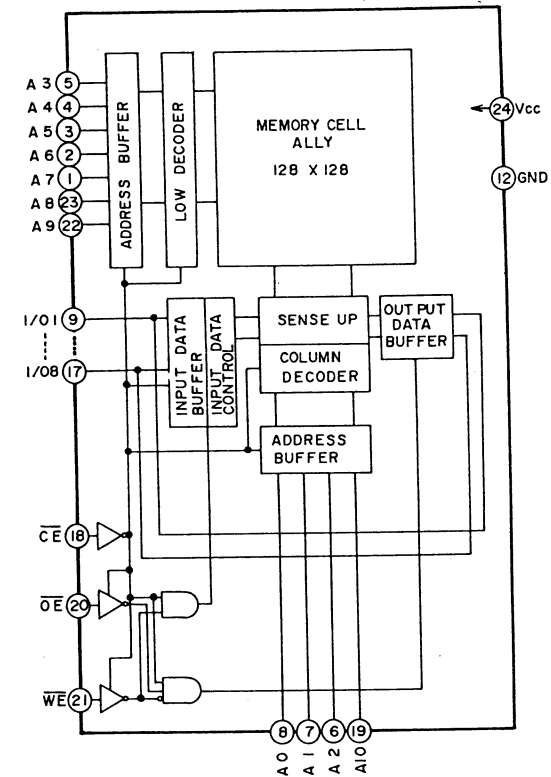

TRUTH TABLE

MODE	CE	OE	WE	I/O
READ CYCLE	L	L	H	DATA OUT
WRITE CYCLE	L	*	L	DATA IN
OUTPUT DISABLE	L	H	*	HIGH IMPEDANCE
INHIBIT	H	*	*	HIGH IMPEDANCE

Pin No.	SYMBOL	I/O	FUNCTIONS
1	S3	O	FLD segment drive output
2	S2	O	
3	S1	O	
4	S0	O	
5	OPEN SW	I	Disc tray open detection switch input
6	CLK	O	Clock output for LSIs
7	DATA	O	Serial data output for LSIs
8	CLOSE SW	I	Disc tray close detection switch input
9	BUS CLK	I	Clock input
10	SCOR	I	Sub code request input
11	SUBQ	I	Sub code-Q data input
12	SENS	I	SENS signal input from IC2
13	CRCF	I	Input of result of sub code-Q error check (CRC)
14	FOK	I	Input of focus OK signal
15	GFS	I	Input of GET FLAME SYNC signal
16	BUS DATA	I	Data input
17	XLT	O	Latch control data output
18	SQCK	O	Reading clock output for sub code-Q
19	BUS CLOCK	O	Bus clock output
20	BUS DATA	O	Bus data output
21	KEY 1	I	Key return 1
22	KEY 2	I	Key return 2
23	SLED IN SW	I	Pick up block innermost detection switch input
24	OSC STOP	O	VCO OSC stop control signal output
25	XRST	O	Reset output for LSIs. H : OSC stop
26	MUTG	O	Mute control output. H : Mute on
27	F OUT	O	Direction control output for loading motor drive IC BA6029AN
28	LASER ON/OFF	O	Laser diode on/off control output. H : Laser on
29	R OUT	O	Direction control output for loading motor drive IC BA6029AN
30	X 1	I	Main clock input
31	X 2	O	Main clock output
32	Vss		GND
33	XT 1		Not used
34	XT 2		Not used
35	LED 1	O	Optical link 1 LED control output. H : LED light
36	LED 2	O	Optical link 2 LED control output. H : LED light
37	LED 3	O	Optical link 3 LED control output. H : LED light
38	LED 4	O	Optical link 4 LED control output. H : LED light
39	RESET	I	Reset signal input
40	1G	O	FLD digit control output
41	2G	O	
42	3G	O	
43	4G	O	
44	5G	O	
45	6G	O	
46	7G	O	
47	8G	O	
48			Not used
49			Not used
50	S15	O	FLD segment control output
51	S14	O	
52	S13	O	
53	S12	O	
54	S11	O	
55	S10	O	
56	VOL AD		-30 V
57	VP PRE		-4 V
58	S9	O	FLD segment control output
59	S8	O	
60	S7	O	
61	S6	O	
62	S5	O	
63	S4	O	
64	Vdd		